



INSTRUCTION BULLETIN

No. 9008708
Machine: T16
Published: 06-2012
Rev. 01

NOTE: DO NOT DISCARD the Parts List from the Instruction Bulletin. Place the Parts List in the appropriate place in the machine manual for future reference. Retaining the Parts List will make it easier to reorder individual parts and will save the cost of ordering an entire kit.

NOTE: Numbers in parenthesis () are reference numbers for parts listed in Bill of Materials.

Installation instructions for **kit number 9008707**

SYNOPSIS:

This kit contains the parts needed install the optional Pre-Sweep assembly onto T16 scrubbers. Please follow step-by-step instructions.

SPECIAL TOOLS / CONSIDERATIONS: NONE

(Estimated time to complete: 2 hours)



PROTECT THE ENVIRONMENT

Please dispose of packaging materials, old machine components, and hazardous fluids in an environmentally safe manner according to local waste disposal regulations.

Always remember to recycle.

PREPARATION:

1. Park the machine on a clean level surface, turn off the machine, and remove the key.

FOR SAFETY: Before leaving or servicing machine, stop on level surface, turn off machine, and remove key.

2. Disconnect the battery cables from the batteries.

 **WARNING: Always disconnect battery cables from machine before working on electrical components.**

INSTALLATION:

1. Remove the head headlight disk and grommet from the front shroud. discard the headlight disk and grommet. Refer to Fig. 1.

Machines equipped with optional headlight only: Remove the headlight assembly from the front shroud. Discard the headlight assembly. Refer to Fig. 1.

2. Pull the main wire harness Pre-Sweep connectors through the hole in the front shroud where the light or disk were previously installed. (Fig. 1)
3. Use three SEMS M10 hex screws (3) and one M10 hex nut (4) to install the right Pre-Sweep mounting plate (1) to the frame of the machine. (Fig. 1)
4. Use three SEMS M10 hex screws (3) and one M10 hex nut (4) to install the left Pre-Sweep mounting plate (2) to the frame of the machine. (Fig. 1)
5. Position the Pre-Sweep assembly (11) near the front of the machine. (Fig. 1)
6. Connect the Pre-Sweep harness to the main wire harness. (Fig. 1 / Fig. 3)
7. Push the Pre-Sweep assembly (11) against the front of the machine.
8. Use six SEMS M10 hex screws (3) to install the Pre-Sweep assembly (11) onto the right and left Pre-Sweep mounting plates (1) (2) installed in the previous two steps. (Fig. 1)

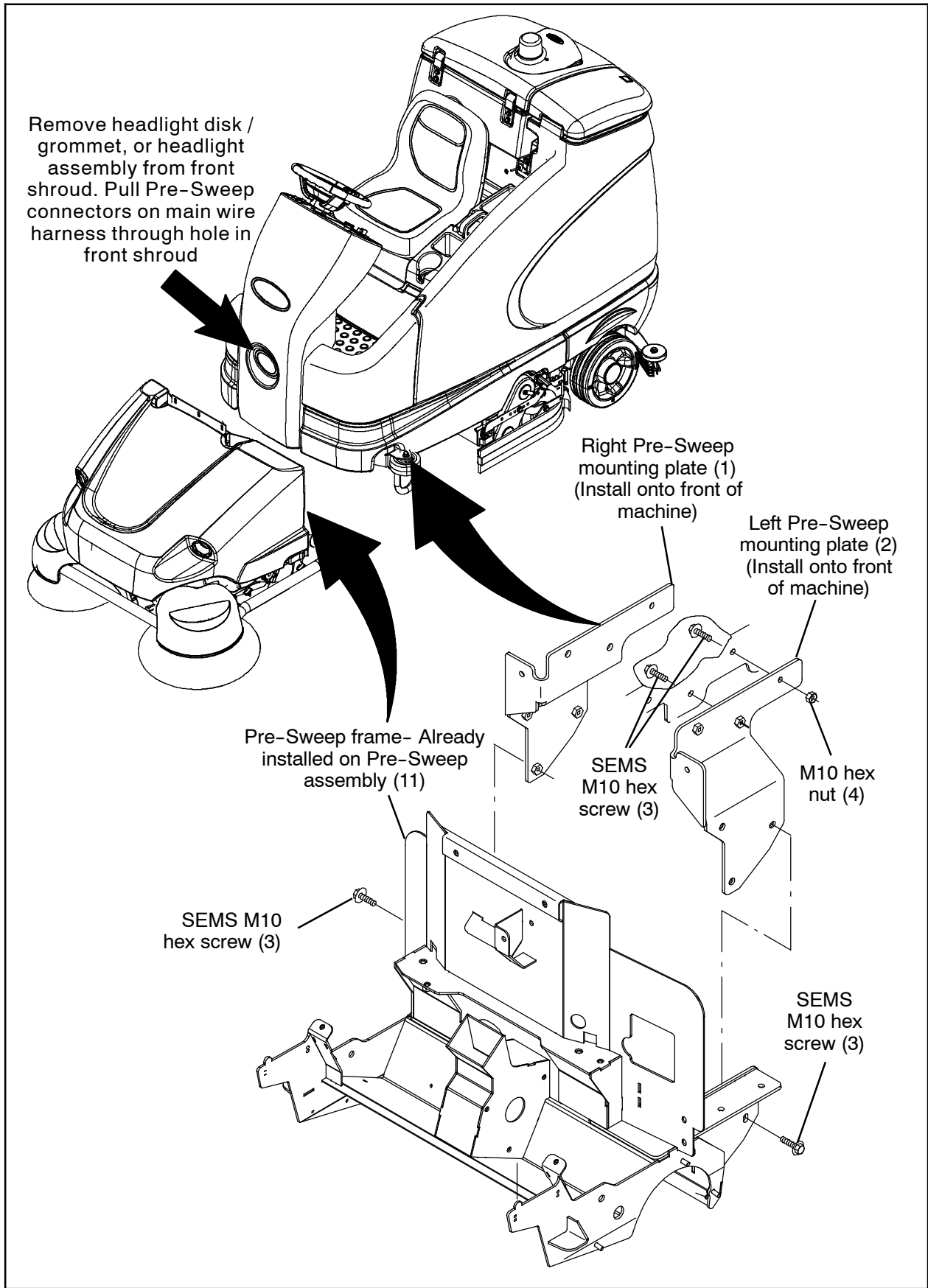

FIG. 1

9. Remove the hardware holding the console panel to the front shroud and carefully pull the console panel from the shroud. Do not break any wire / cable connections when pulling the console panel from the front shroud. Set the hardware aside. (Fig. 2)
10. Insert the rocker switch (5) into the console panel. (Fig. 2)
11. Connect the main harness to the rocker switch. (Fig. 2 / Fig. 3 / Fig. 5)
12. Reinstall the console panel onto the front shroud. (Fig. 2)
13. Remove the hardware holding the electrical panel to the steering channel weldment and carefully remove the electrical panel from the steering channel weldment. Do not break any wire / cable connections when pulling the electrical panel from the steering channel weldment. Set the hardware aside. (Fig. 2)
14. Install the 25-Amp circuit breaker (6) onto the electrical panel (CB 19). (Fig. 2)
15. Insert the 15-Amp circuit breaker (8) into the electrical panel (CB 16). (Fig. 2)
16. Install a circuit breaker boot (9) onto the 15-Amp circuit breaker (8) installed in the electrical plate. (Fig. 2)
17. Connect the main harness to the 25-Amp circuit breaker (6) and 15-Amp circuit breaker (8). (Fig. 2 / Fig. 3 / Fig. 4 / Fig. 5)
18. Reinstall the electrical panel onto the steering channel weldment. (Fig. 2)
19. Insert the 20-Amp circuit breaker (7) into (CB 8) and the 2.5-Amp circuit breaker (10) into (CB 3) in the circuit breaker mounting plate located in the battery compartment. (Fig. 2)
20. Install a circuit breaker boot (9) onto the 20-Amp circuit breaker (7) and 2.5-Amp circuit breaker (10) installed in the circuit breaker mounting plate. (Fig. 2)
21. Connect the main harness to the 20-Amp circuit breaker (7) and the 2.5-Amp circuit breaker (10) installed in the circuit breaker mounting plate. (Fig. 2 / Fig. 5 / Fig. 6)

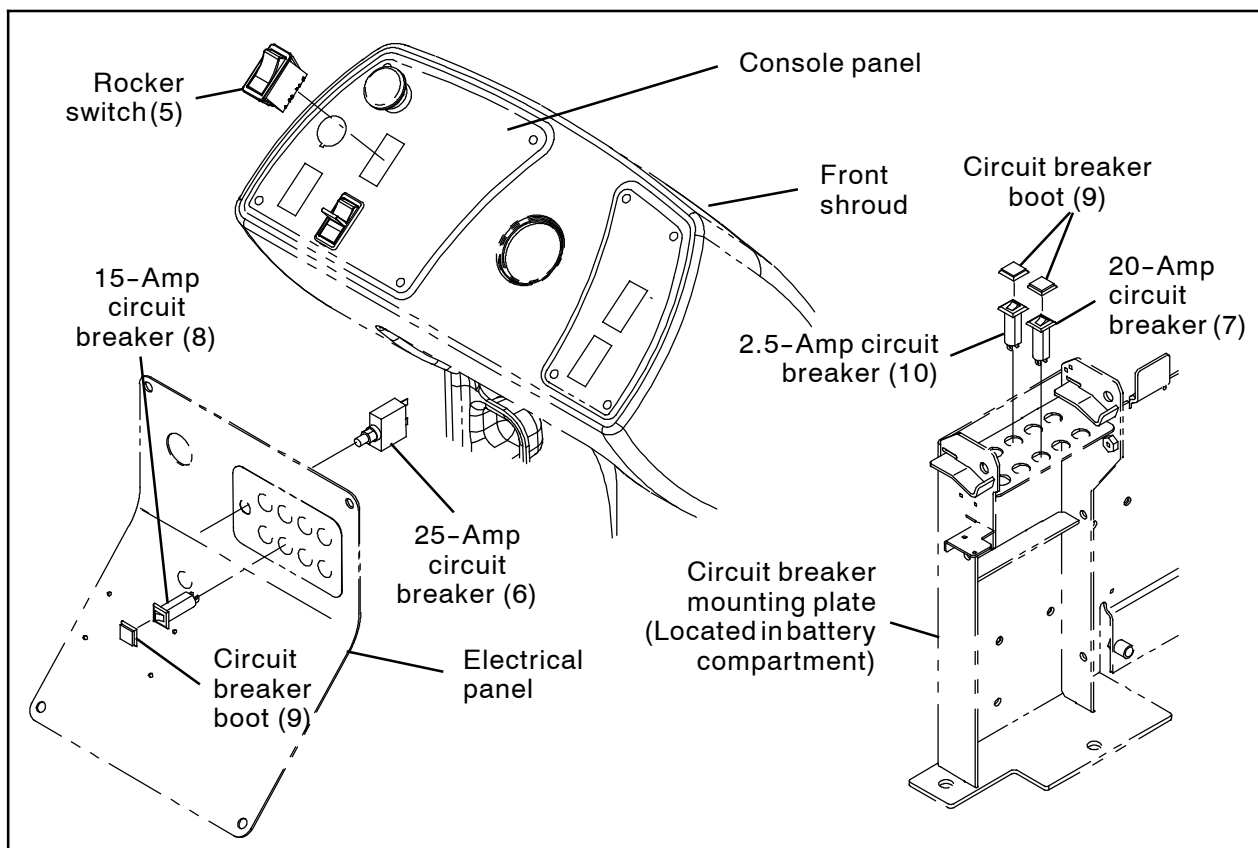

FIG. 2

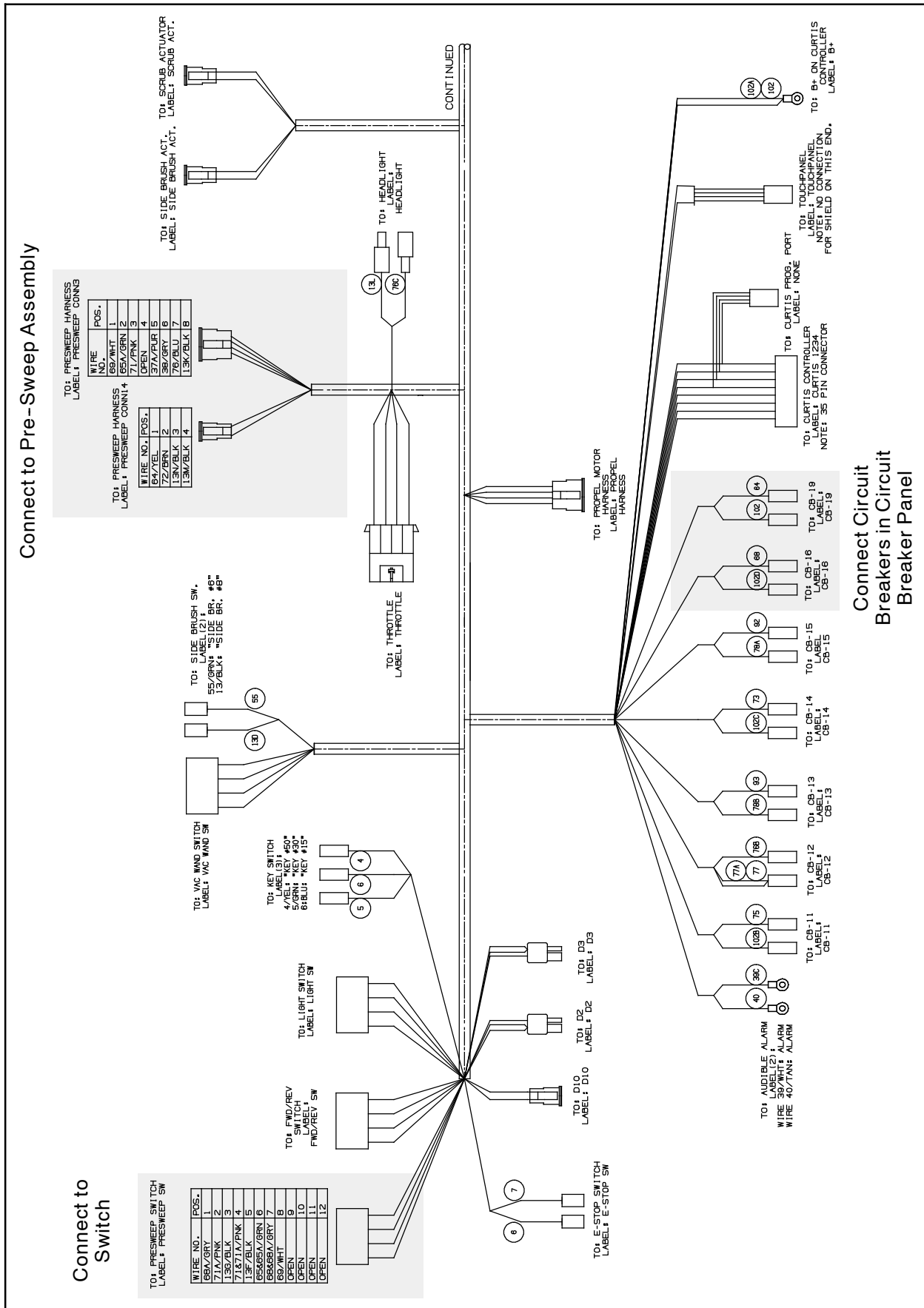

FIG. 3

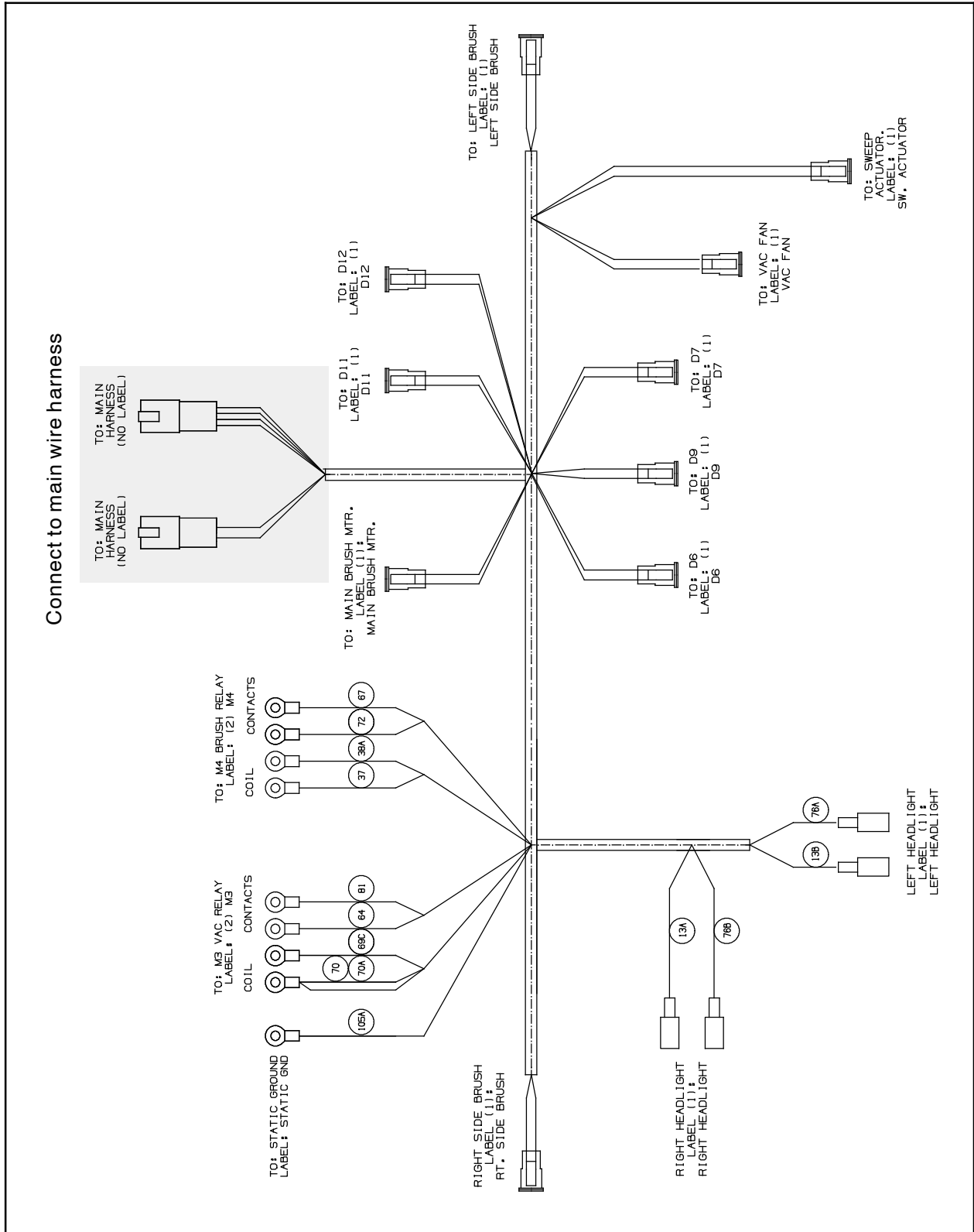

FIG. 4

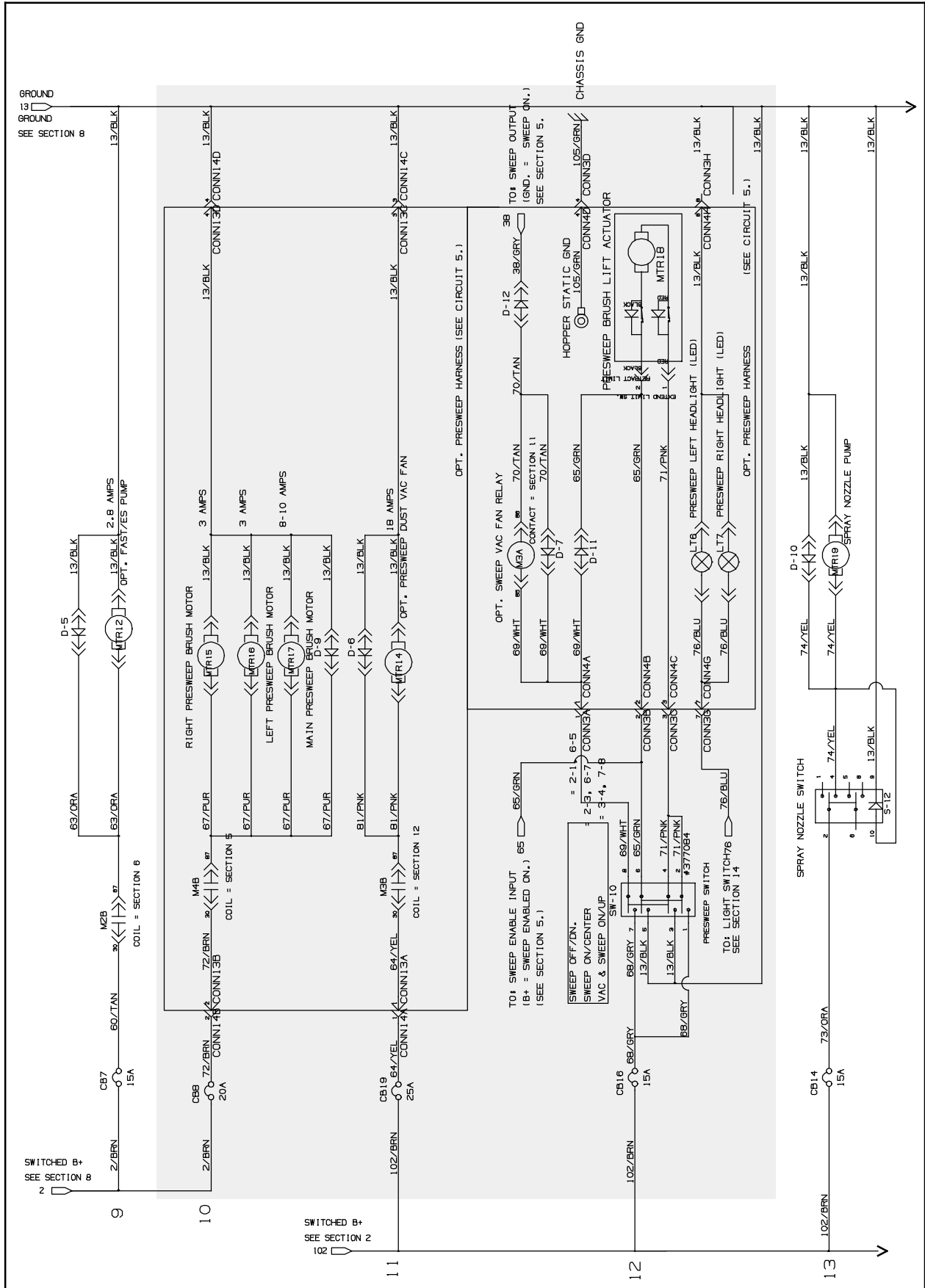

FIG. 5

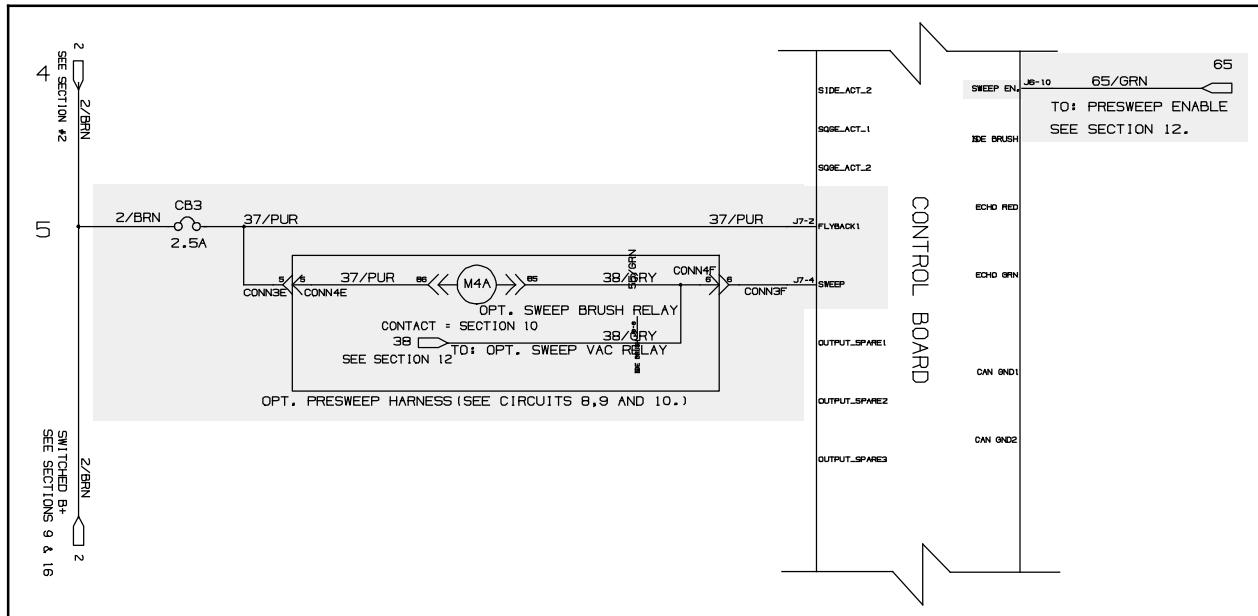

FIG. 6

22. Reconnect the battery cables to the batteries.
23. Start the machine, raise the Pre-Sweep to fully raised position, and turn off the machine.
24. Install the disk side brushes and cylindrical main brush into the Pre-Sweep assembly. Refer to the *MAINTENANCE* section in the Operator Manual for installation instructions.
25. Install the vacuum debris bag into the Pre-Sweep assembly. Refer to *EMPTY THE PRE-SWEEP DEBRIS HOPPER* in the Operator Manual for installation instructions.
26. Start and test the machine. Operate the Pre-Sweep assembly to ensure it functions. Refer to the Operator Manual for additional information about operating the Pre-Sweep assembly.

Bill Of Materials For Pre-Sweep Kit, DI [T16] -9008707

Ref.	Tennant Part No.	Description	Qty.	
▽	9008707	Pre-Sweep Kit, DI [T16]	1	
▲	1	1059918	Plate, Frame, Mtg, RH	1
▲	2	1060115	Plate, Frame, Mtg, Pre-Sweep, LH	1
▲	3	1037358	Screw, Hex, M10 X 1.50 X 35, 9.8, SEMS	12
▲	4	41430	Nut, Hex, Lock, M10 X 1.5, NL	2
▲	5	377084	Switch, Rocker, Prgrsv	1
▲	6	383724	Circuit Breaker, 25.0a, Resettable	1
▲	7	1064189	Circuit Breaker, 20.0a, Resettable	1
▲	8	1064188	Circuit Breaker, 15.0a, Resettable	1
▲	9	1064191	Boot, Circuit Breaker	3
▲	10	1064184	Circuit Breaker, 02.5A, Resettable	1
▲	11		Pre-Sweep Assembly (see Parts Manual)	1

TENNANT COMPANY
P. O. Box 1452
Minneapolis, MN 55440-1452